

Motorcycle Batteries



intAct Bike-Power GEL

Sealed maintenance-free GEL battery | electrolyte thickened into a gel-like mass | wet charged



FOR HEAVY LOADS, INCLUDING ABS

Delivers 30% more starting power for modern motorcycles with many electrical consumers and covers consumption peaks. Low self-discharge, bike starts reliably even after up to 3 months. Our recommendation if many consumers are installed or the motorcycle is rarely used.

- » **Even more cycle-resistant** than Bike-Power AGM and Bike-Power SLA of the same box size.
- » **Low self-discharge.** For seasonal use.
- » **Very high vibration-resistance.** Electrolyte thickened into a gel-like mass.
- » **30% more starting power** than a conventional battery of the same box size. For motorcycles with many consumers, including ABS.
- » **Sealed maintenance-free** battery. Refilling is neither possible nor necessary.
- » Wet charged. **Ready to use.**

Datasheet

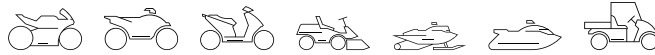

Artnum.	GEL12-9-4B-1
Japan-Code	12N9-4B1, 50914
Volt	12V
Capacity	9 AH (c20)
CCR - 18°C (EN)	170 A (EN)
Electrolyte	diluted sulphuric acid
Electrolyte density	1,28 +/- 0,01 kg/l (25°)
Size (LxWxH)	137 x 76 x 140 mm
Weight	3,6 kg
Pos. of Terminal	1

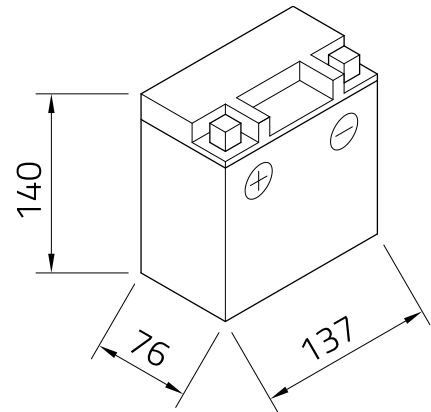
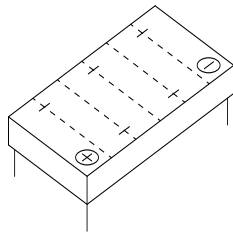

Technology Sealed maintenance-free GEL battery | electrolyte thickened into a gel-like mass | wet charged

Terminal B

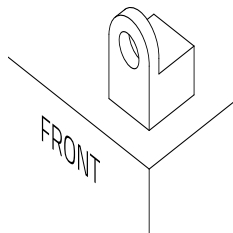

Base plate -

As of 04.04.2023



Stefan Keckeisen
Akkumulatoren e.K.

Europastraße 9
87700 Memmingen

Fon +49 (0) 8331-94444-0
Fax +49 (0) 8331-94444-9

info@intact-batterien.de
www.intact-batterien.de