

Motorcycle Batteries

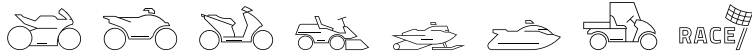

intAct Bike-Power GEL HVT-HD

Sealed maintenance-free GEL with extra compressed plate packs | electrolyte immobilized by gel-additive



EXTREMELY VIBRATION-RESISTANT POWER PACKAGE

Low self-discharge and particularly high currents make this battery the perfect choice for Harleys and other high-capacity bikes with lots of extra equipment. Our recommendation for motorcycles with a lot of consuming equipment and powerful engines.

- » Perfect for **Harleys** and other bikes with **high-capacity 2-cylinder engines**.
- » **Highest cold cranking aper:** For two-wheelers with high energy requirements, e.g. due to ABS safety technology.
- » **Extremely vibration-resistant.** Plate packs compressed and precisely fitted into the battery box.
- » Robust housing made of impact-resistant plastic.** For heavy mechanical stress.
- » **Leak-proof. Can be installed at an angle** because the electrolyte is immobilized by gel-additive.
- » **Sealed maintenance-free.**

Datasheet

BIKE POWER **GEL HVT-HD**



Artnum. **GEL-HVT-08**

Japan-Code **GHD14H-BS**

Volt 12V

Capacity 14 AH (c20)

CCR - 18°C (EN) 255 A (EN)

Electrolyte diluted sulphuric acid

Electrolyte density 1,28+/- 0,01 Kg/l (25°)

Size (LxWxH) 150 x 87 x 145 mm

Weight 4,6 kg

Pos. of Terminal 1

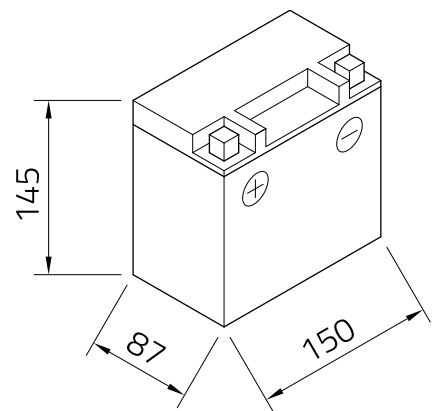
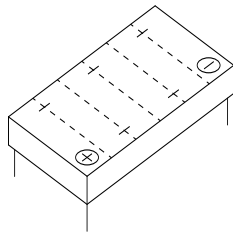

Technology Sealed maintenance-free GEL with extra compressed plate packs | electrolyte immobilized by gel-additive

Terminal **screw terminal**

Base plate -

As of 15.08.2022