

Motorcycle Batteries



intAct Bike-Power GEL HVT-HD

Sealed maintenance-free GEL with extra compressed plate packs | electrolyte immobilized by gel-additive



EXTREMELY VIBRATION-RESISTANT POWER PACKAGE

Low self-discharge and particularly high currents make this battery the perfect choice for Harleys and other high-capacity bikes with lots of extra equipment. Our recommendation for motorcycles with a lot of consuming equipment and powerful engines.

- » Perfect for **Harleys** and other bikes with **high-capacity 2-cylinder engines**.
- » **Highest cold cranking aper:** For two-wheelers with high energy requirements, e.g. due to ABS safety technology.
- » **Extremely vibration-resistant.** Plate packs compressed and precisely fitted into the battery box.
- » Robust housing made of impact-resistant plastic.** For heavy mechanical stress.
- » **Leak-proof. Can be installed at an angle** because the electrolyte is immobilized by gel-additive.
- » **Sealed maintenance-free.**

Datasheet

BIKE POWER **GEL HVT-HD**



Artnum.	GEL-HVT-03
Japan-Code	GHD14HL-BS
Volt	12V
Capacity	14 AH (c20)
CCR - 18°C (EN)	255 A (EN)
Electrolyte	diluted sulphuric acid
Electrolyte density	1,28+/- 0,01 Kg/l (25°)
Size (LxWxH)	150 x 87 x 145 mm
Weight	4,6 kg
Pos. of Terminal	0

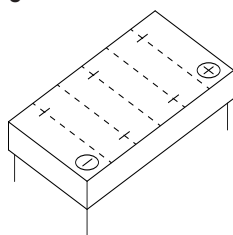

Technology	Sealed maintenance-free GEL with extra compressed plate packs electrolyte immobilized by gel-additive
Terminal	screw terminal
Base plate	-

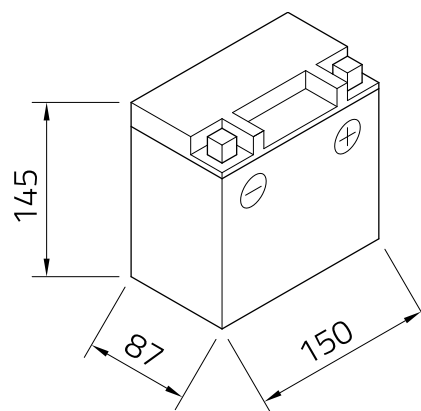

As of 15.08.2022