

# Motorcycle Batteries

BIKE  
POWER **CLASSIC**



## intAct Bike-Power Classic

Low-maintenance lead-acid battery | dry-charged, acid pack included



**intAct**  
BATTERY - POWER

## POWERFUL AND SUSTAINABLE

The solid battery without frills delivers high starting power, with regular maintenance it achieves a long service life and has excellent recycling properties. Our recommendation for an inexpensive standard motorcycle battery.

- » Reliable starting power at an excellent price.
- » Replacement recommendation for broken flooded battery.
- » Central degassing.
- » Only to be installed upright, as flooded battery with vent caps.

# Datasheet

BIKE  
POWER **CLASSIC**



Artnum.	00714S
Japan-Code	B39-6, 6N7-1
Volt	6V
Capacity	7 AH (c20)
CCR - 18°C (EN)	30 A (EN)
Electrolyte	diluted sulphuric acid
Electrolyte density	1,28 +/- 0,01 kg/l (25°)
Size (LxWxH)	126 x 48 x 126 mm
Weight	1,8 kg
Pos. of Terminal	0

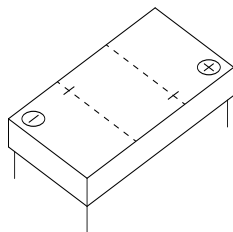

**Technology** Low-maintenance lead-acid battery | dry-charged, acid pack included

**Terminal** B

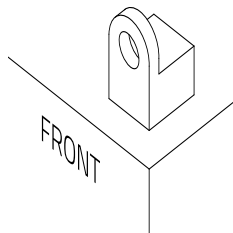

**Degassing** 6

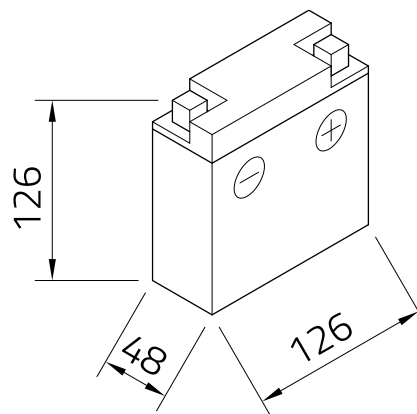
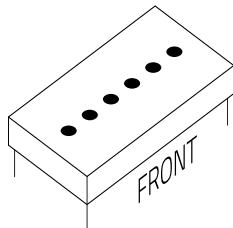

As of 18.08.2022

**KECKEISEN**  
AKKUMULATOREN

Stefan Keckeisen  
Akkumulatoren e.K.

Europastraße 9  
87700 Memmingen

Fon +49 (0) 8331-94444-0  
Fax +49 (0) 8331-94444-9

info@intact-batterien.de  
www.intact-batterien.de