

Starter Batteries

START POWER



intAct Start-Power

Calcium or hybrid battery (Ca/Ca or Sb/Ca)



intAct
BATTERY - POWER

TOP PERFORMANCE AT A GREAT PRICE

Designed for performance and extreme high current capability offering perfect value for money. For almost all passenger cars, coaches, trucks and agricultural machinery. Our recommendation for a solid battery when cost is a major consideration.

- » Durable, safe and reliable.
- » **2 versions:** Calcium battery (Ca/Ca) wet charged (GUG) or dry-charged (TV) hybrid battery (Sb/Ca).
- » Low maintenance or maintenance free.
- » Wet charged version in part with double lid for increased leak protection and vapour condensation.
- » All truck/utility and Asia models only low-maintenance (with vent caps on top).
- » Not suitable for vehicles with charging voltage 14.8 volts.

Datasheet

START POWER



Artnum. 62523GUG

Japan-Code keine

Volt 12V

Capacity 125 AH (c20)

CCR - 18°C (EN) 900 A (EN)

Electrolyte diluted sulphuric acid

Electrolyte density 1,28 +/- 0,01 Kg/l (25° C)

Size (LxWxH) 286 x 269 x 230 mm

Weight 30,4 kg

Pos. of Terminal 2

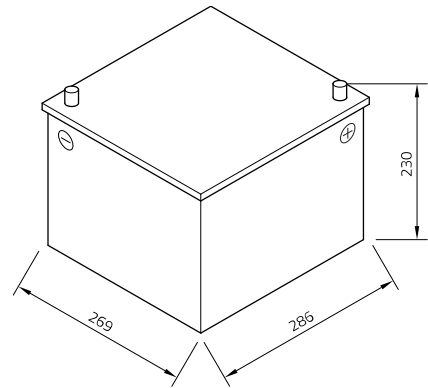
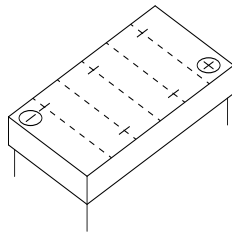

Technology Calcium or hybrid battery (Ca/Ca or Sb/Ca)

Terminal 1

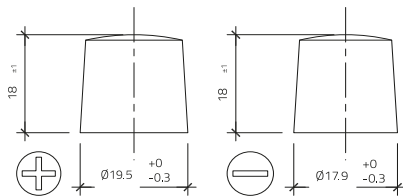

Base plate -

As of 12.09.2022